

Pneumatic Grip

TA83 – 7kN

TA83 Pneumatic grip

- Clamping force: 7 kN /7bar (max. 16 bar)
- Standard temperature range: 0 °C - +70°C
with Viton: -70°C - +180°C
Further temperature ranges on request
- Body made of aluminum
- Pneumatic internal thread connection: 1/8"
- Weight 3.2 kg each without jaws
- Scope of supply: 1 pair



Jaws for TA83: Scope of supply: 1 Set = 4 jaws

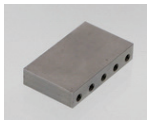

- Blank (smooth) jaws**
- Suitable for own further treatments
 - Steel-blanks without coating

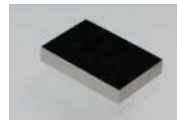

- Rubber coated jaws**
- 1 mm rubber coating (NBR)
 - Nickel-plated

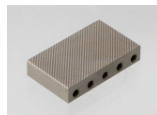

- Pyramid jaws (serrated)**
- Pyramids 1.2x45
 - Hardened steel 58HRC
 - Nickel-plated°

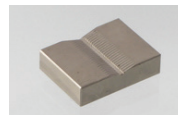

- V-jaws**
- For all kinds of round samples
 - Tooth pitch 1.2 mm
 - Hardened steel 58HRC
 - Nickel-plated



- Wave jaws (corrugated)**
- For flexible materials
 - Wave 5 mm
 - Hardened steel 58HRC
 - Nickel-plated

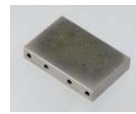

- Diamond coated jaws**
- Clamping surface coated with synthetic diamonds D91 (170/200 mesh)
 - Nickel-plated

Item number	Surface	Clamping surface H x W	Opening	Temperature range	Weight/ 1 pair
TH83-B	Blank jaws	40 x 60 mm	0 – 10 mm	+20 °C ... +180°C	0.35 kg
TH83-BG	Rubber-coated jaws	40 x 60 mm	0 – 8 mm	- 70 °C ... +70°C	0.36 kg
TH83-BP	Pyramid jaws	40 x 60 mm	0 – 10 mm	- 70 °C ... +180°C	0.33 kg
TH83-BV3	V-jaws	Clamping height 40 mm	3 – 10 mm Ø	- 70 °C ... +180°C	0.35 kg
TH83-BV6	V-jaws	Clamping height 40 mm	6 – 10 mm Ø	- 70 °C ... +180°C	0.34 kg
TH83-BW	Wave jaws	40 x 60 mm	0 – 10 mm	- 70 °C ... +180°C	0.40 kg
TH83-BD	Diamond-coated jaws	40 x 60 mm	0 – 10 mm	- 70 °C ... +180°C	0.35 kg
TH83-B100	Blank jaws	40 x 100 mm	0 – 10 mm	+20 °C ... +180°C	0.72 kg
TH83-BG100	Rubber-coated jaws	40 x 100 mm	0 – 3 mm	- 70 °C ... +70°C	0.74 kg
TH83-BP100	Pyramid jaws	40 x 100 mm	0 – 10 mm	- 70 °C ... +180°C	0.69 kg
TH83-BW100	Wave jaws	40 x 100 mm	0 – 10 mm	- 70 °C ... +180°C	0.66 kg
TH83-BD100	Diamond-coated jaws	40 x 100 mm	0 – 10 mm	- 70 °C ... +180°C	0.72 kg

*Rods for openings 10 – 20 mm and 20 – 30 mm are included in the scope of delivery of the grips

**with rods for opening 10 – 20 mm



Thwing-Albert
Instrument Company



TA062322

thwingalbert.com

Pneumatic Grip

TA83 – 7kN

Inset jaws for TA83:

Jaw quick changing system

Inset jaws require carriers (TA83-GT)

Scope of delivery: 1 Set = 4 jaws

Item number	Surface	Clamping surface H x W	Opening*	Temperature range	Weight/ 1 pair
TH83-GT	Carrier	-	-	- 70 °C ... +180°C	0.33 kg
TH83-EBB	Blank insert jaws	50 x 60 mm	0-9 mm	+20 °C ... +180°C	0.29 kg
TH83-EBG	Rubber coated insert jaws	50 x 60 mm	0-7 mm	- 70 °C ... +70°C	0.30 kg
TH83-EBP	Pyramid insert jaws	50 x 60 mm	0-9 mm	- 70 °C ... +180°C	0.28 kg
TH83-EBV4	V insert jaws	Height 50 mm	4-9 mm	- 70 °C ... +180°C	0.29 kg
TH83-EBW	Wave insert jaws	50 x 60 mm	0-9 mm	- 70 °C ... +180°C	0.26 kg
TH83-EBD	Diamond coated insert jaws	50 x 60 mm	0-9 mm	- 70 °C ... +180°C	0.29 kg
TH83-GT100	Carrier	-	-	- 70 °C ... +180°C	0.69 kg
TH83-EB100	Blank insert jaws	50 x 100 mm	0-9 mm	+20 °C ... +180°C	0.63 kg
TH83-EBG100	Rubber coated insert jaws	50 x 100 mm	0-3 mm	- 70 °C ... +70°C	0.65 kg
TH83-EBP100	Pyramid insert jaws	50 x 100 mm	0-9 mm	- 70 °C ... +180°C	0.60 kg
TH83-EBW100	Wave insert jaws	50 x 100 mm	0-9 mm	- 70 °C ... +180°C	0.57 kg

*Rods for opening 9–19 mm are included in the scope of delivery of the grips

Jaws with other dimensions and surface coatings on request

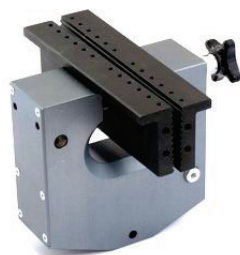
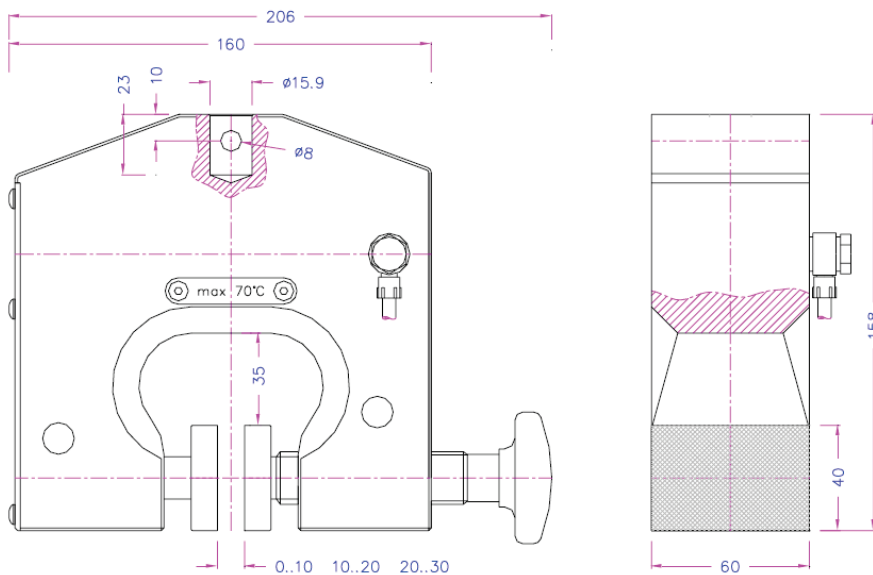

TA83 + TA83-BW200

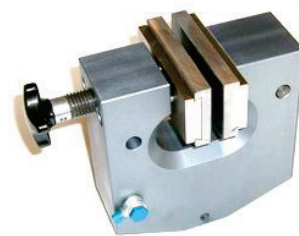

TA83 + TA83-GT100 + TA83-EBG100



Thwing-Albert
Instrument Company







TA062322

thwingalbert.com

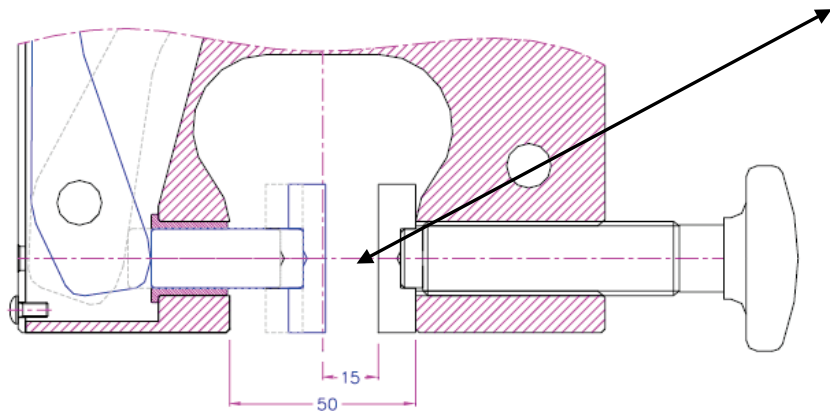
Pneumatic Grip

TA83 – 7kN

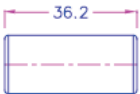

0-5		For Sample 0 – 10 mm
5-10		For Sample 10 – 20 mm
10-15		For Sample 20 – 30 mm

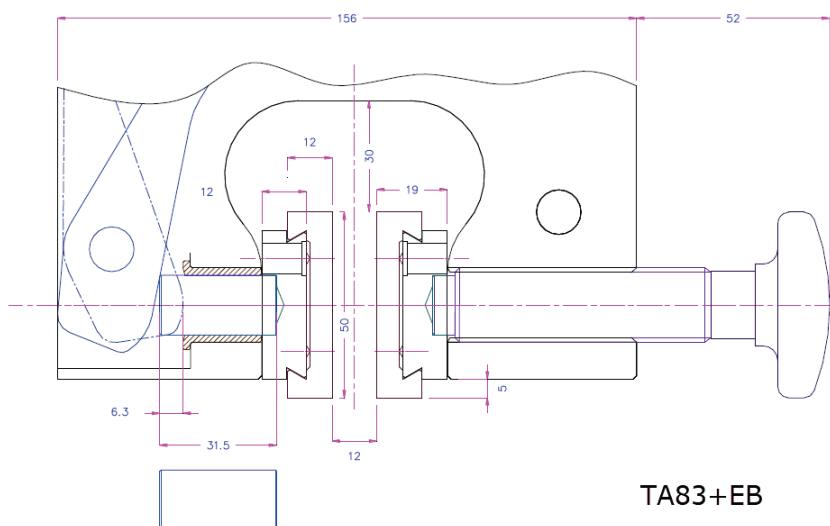

TA83+EB

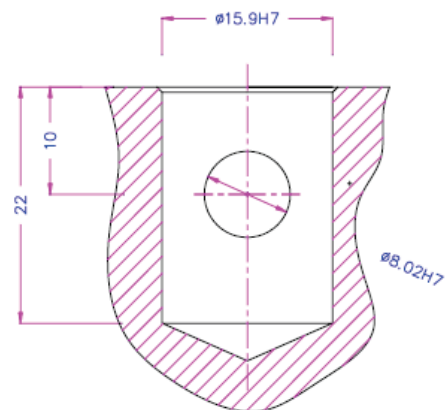

Af159 (5/8")

